

Building instructions fuselage-lid

step 1

put together the lid-frame inside the opening of the fuselage for best fitting.
(do not use cyanoacrilate adhesive, frame should be removable afterwards)

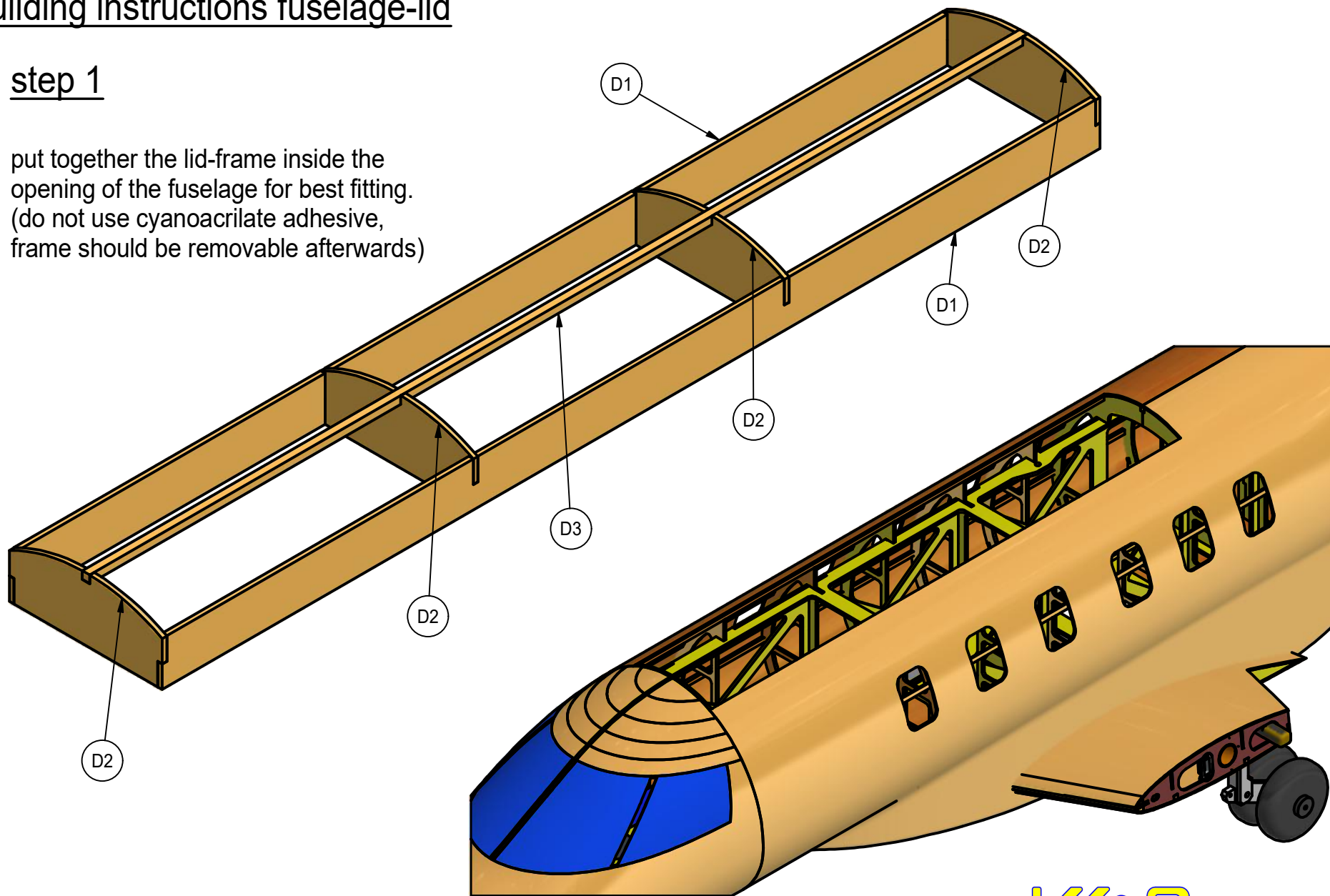

Building instructions fuselage-lid

step 2

planking with balsa 2mm thick
be sure to get a distortion-free lid

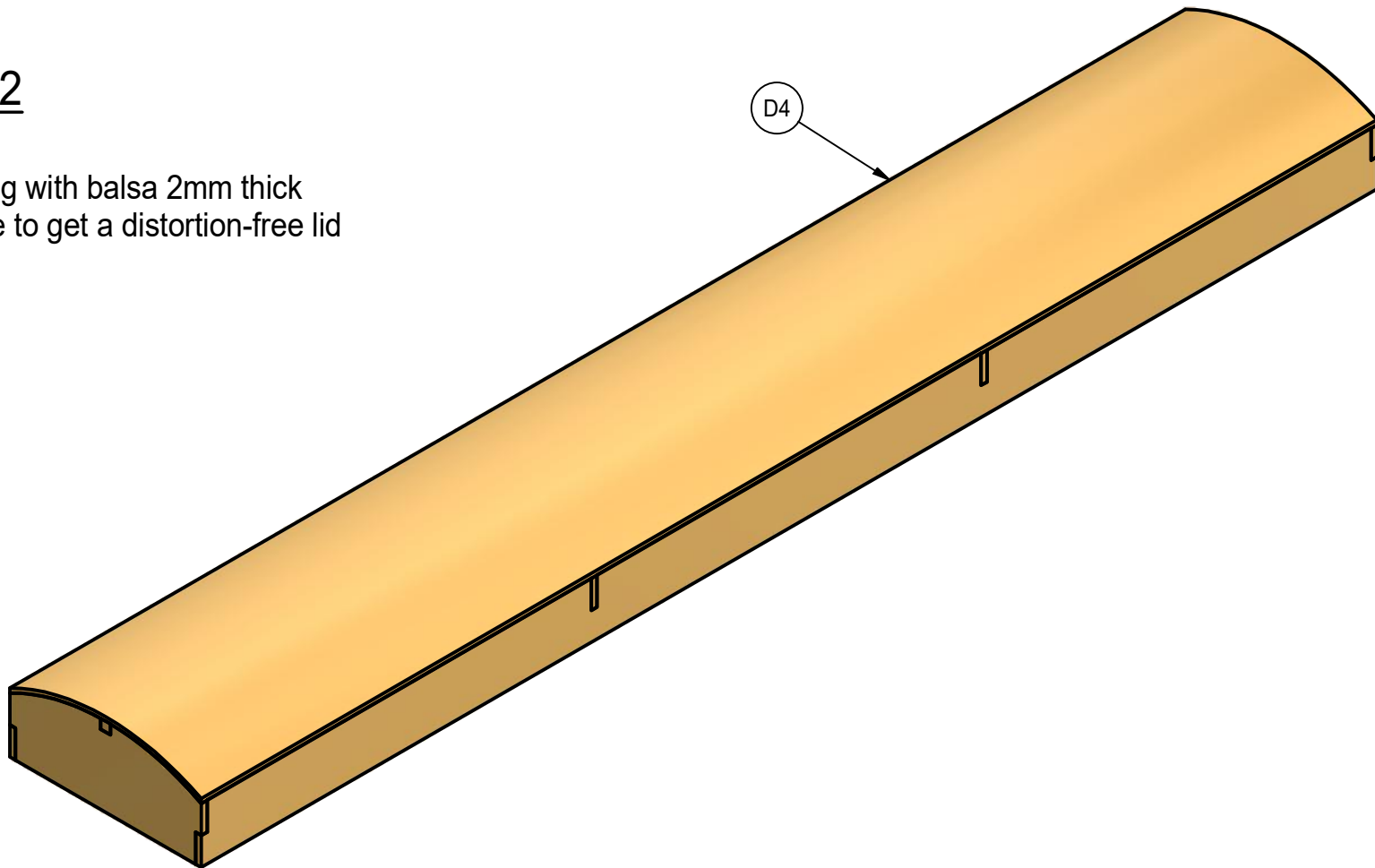

Building instructions fuselage-lid

step 3

lid fastener

glue in baseplates D6

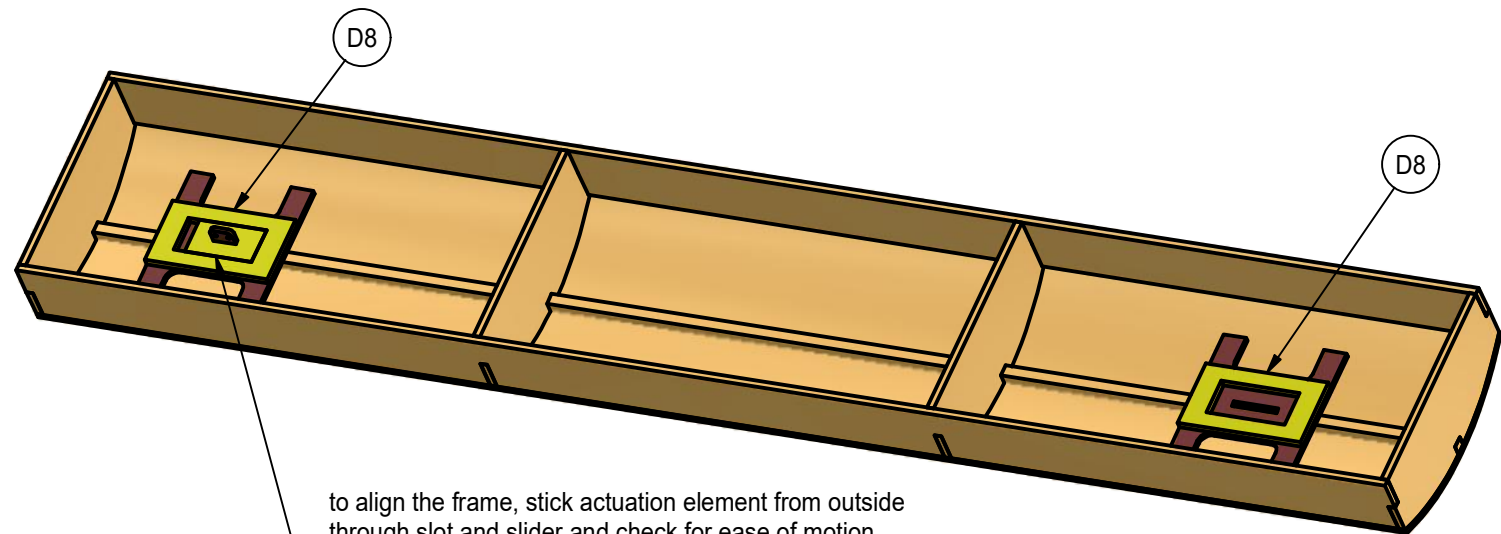
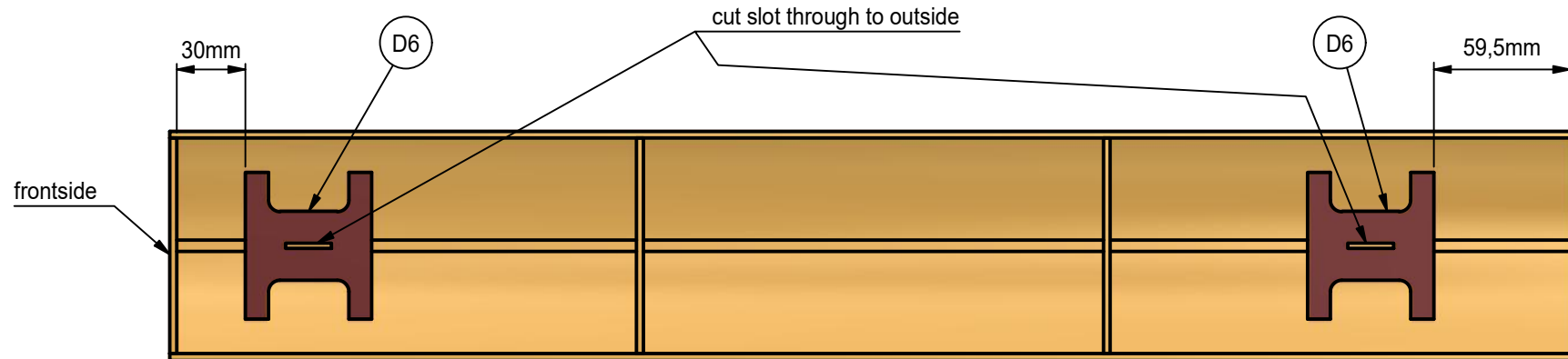

step 4

lid-fastener

fix frames D8

to align the frame, stick actuation element from outside through slot and slider and check for ease of motion. DO NOT GLUE slider and actuator together, remove to let glue of frame cure.

Building instructions fuselage-lid

step 5 lid-fastener completion

when you finish with heat shrinking foil,
it's easier to do it before completion of
the fastener

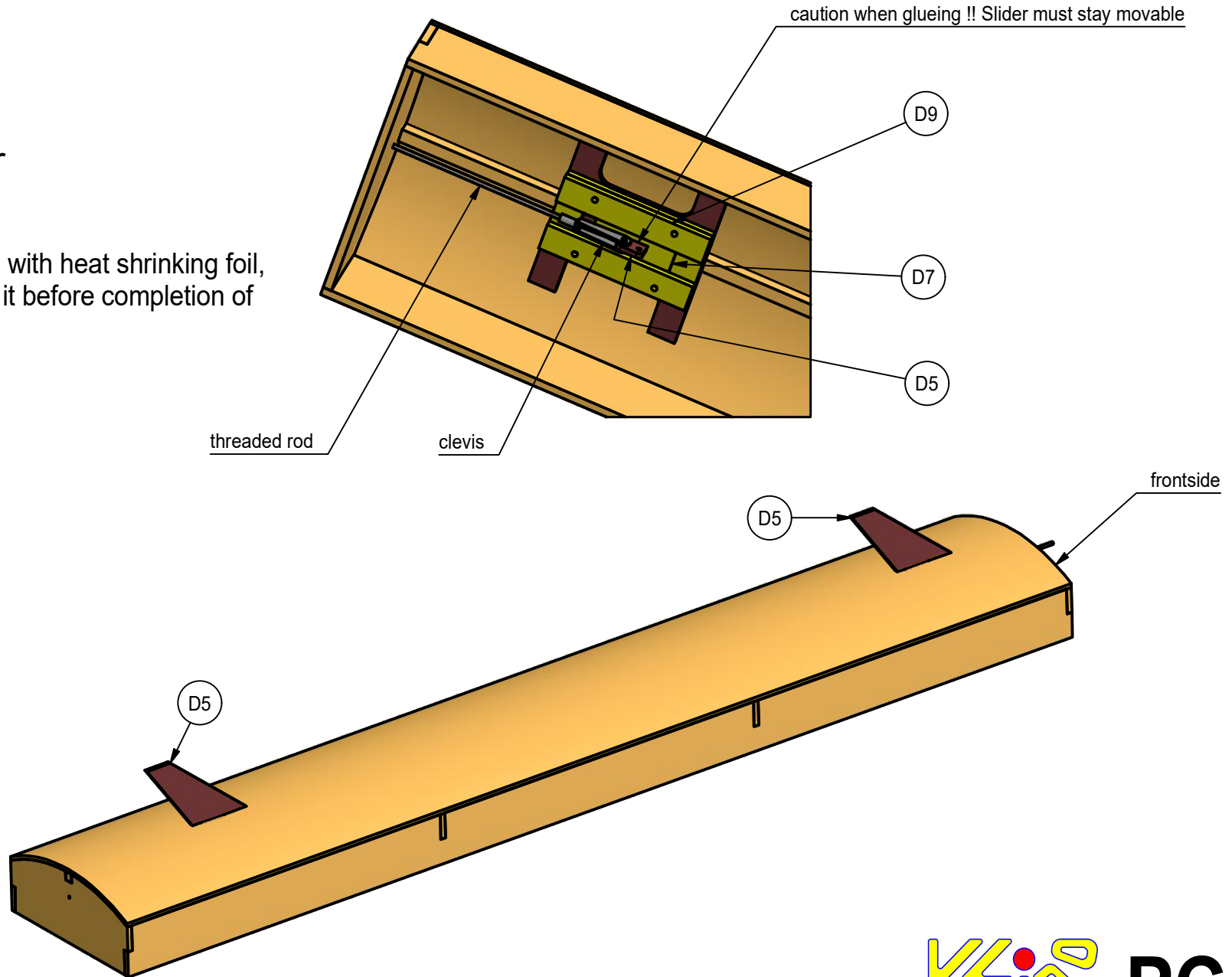

Building-instructions tailend

step 1

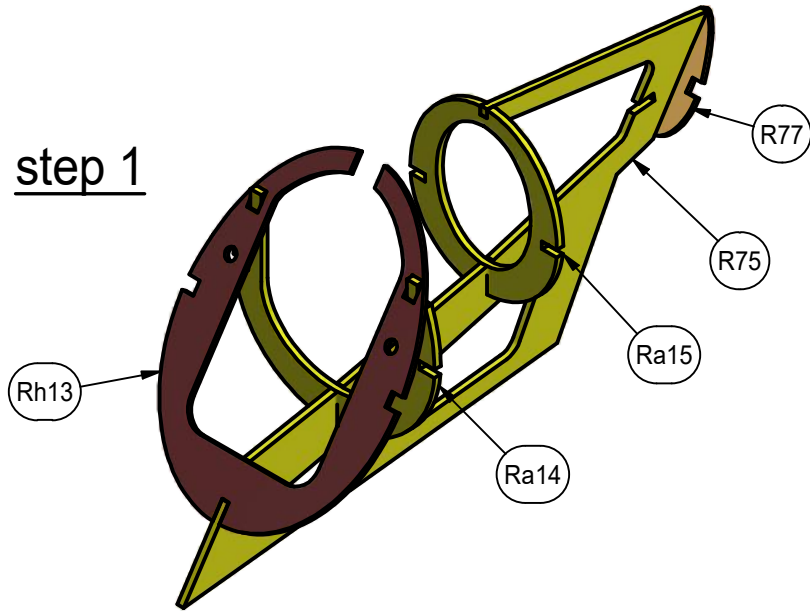

step 2

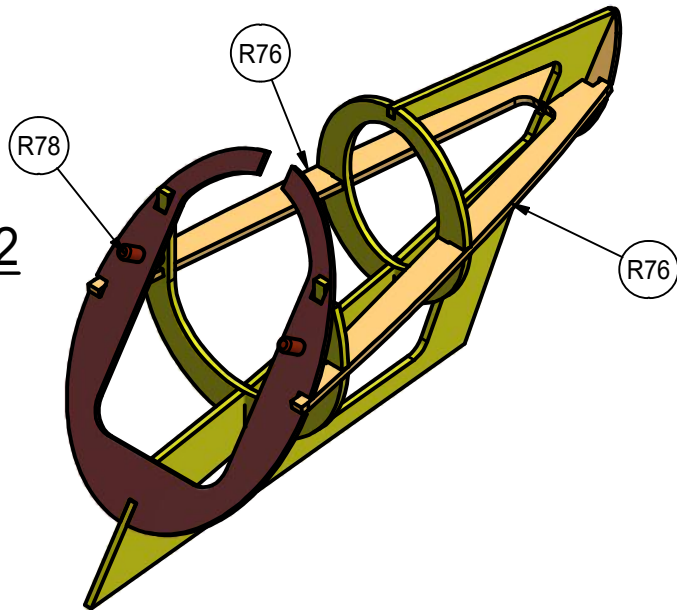

step 3

planking with balsa 2mm thick

