

Building instructions wing

Be sure to build one left and one right wing

step 1

preparation of the spar

align outer surfaces of F15 and F33

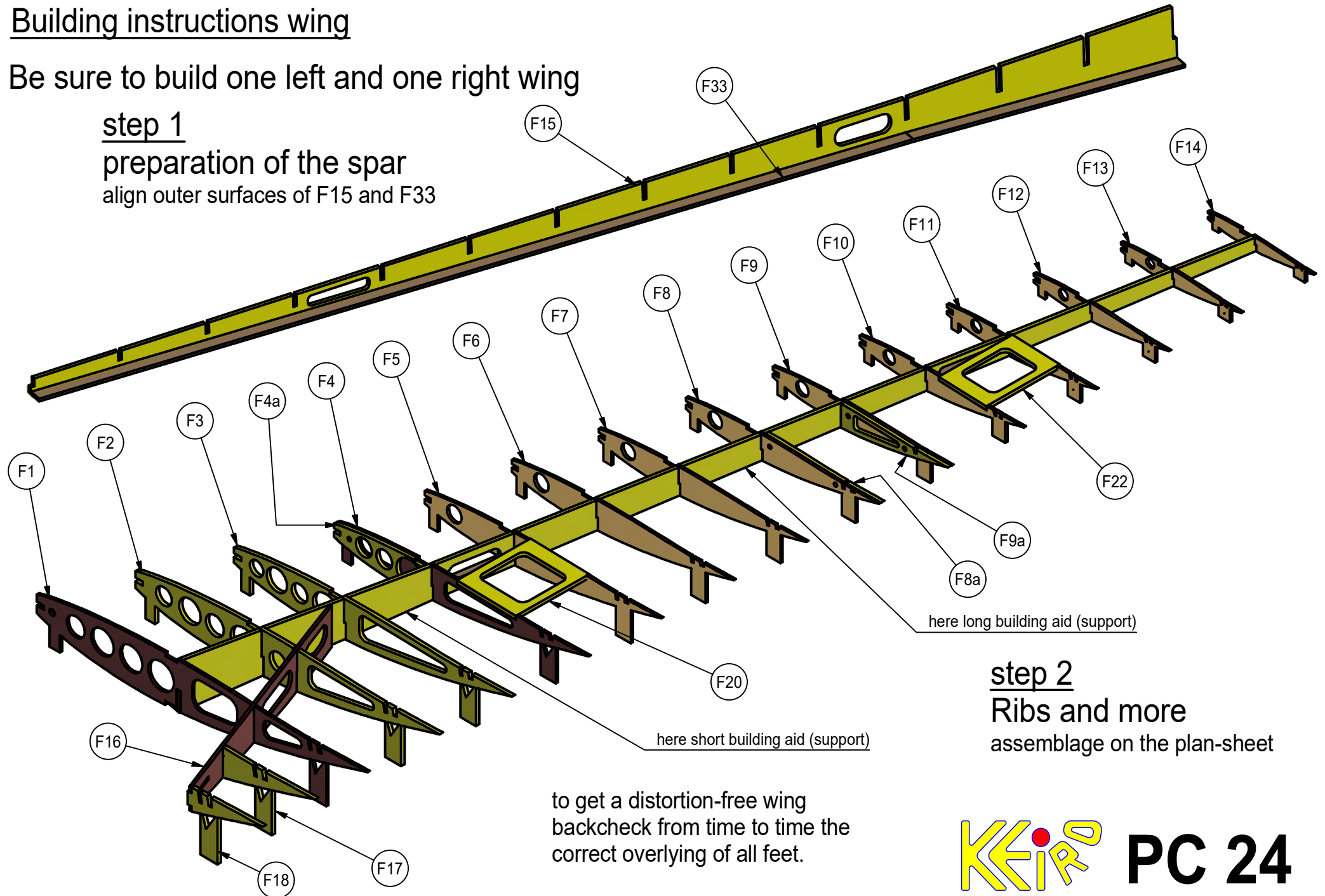

step 2

Ribs and more assemblage on the plan-sheet

to get a distortion-free wing
backcheck from time to time the
correct overlying of all feet.

Building instructions wing

step 3
ledges and more

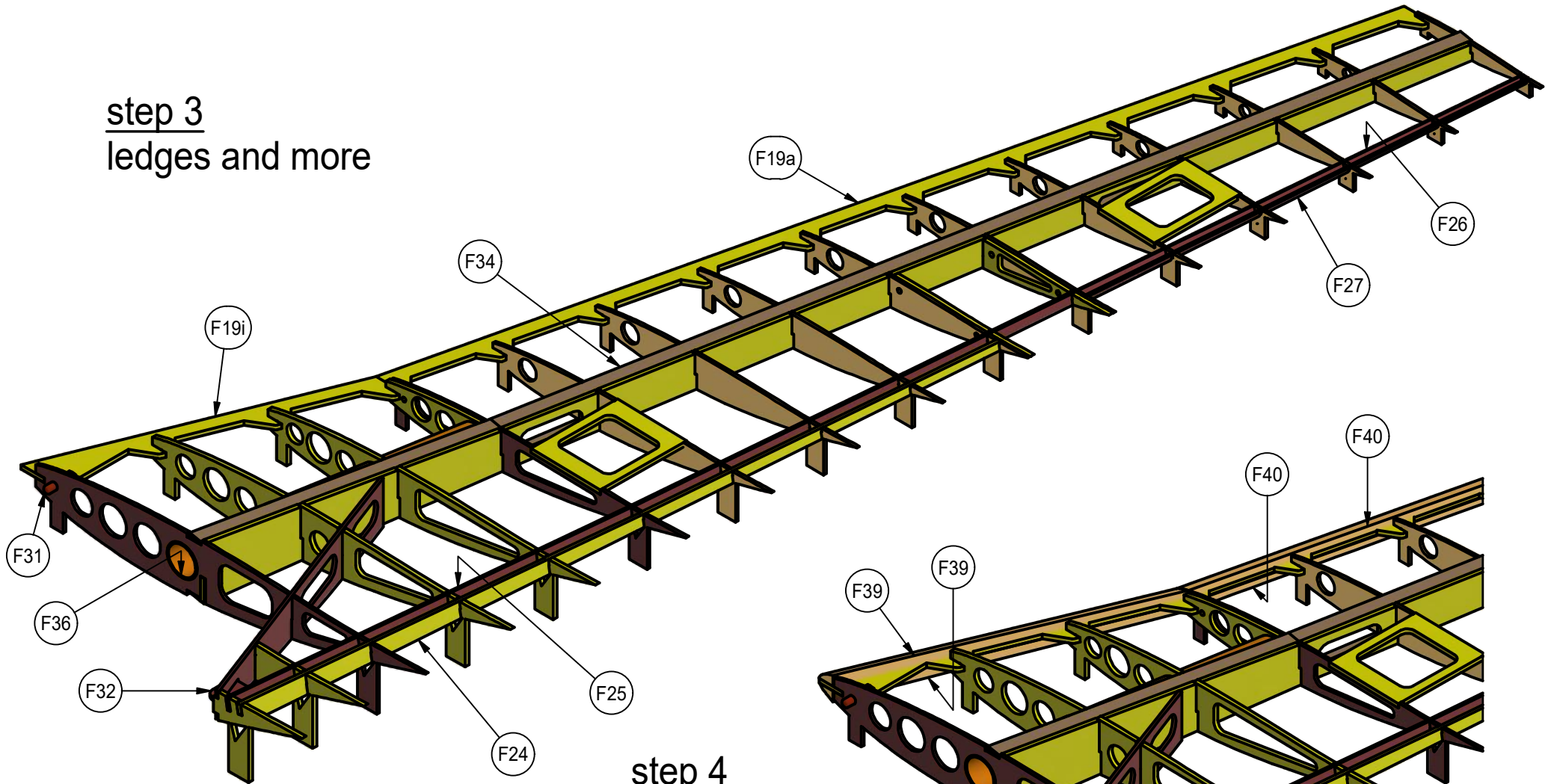

step 4
leading edge
(shape F39 to fit wing section before planking)

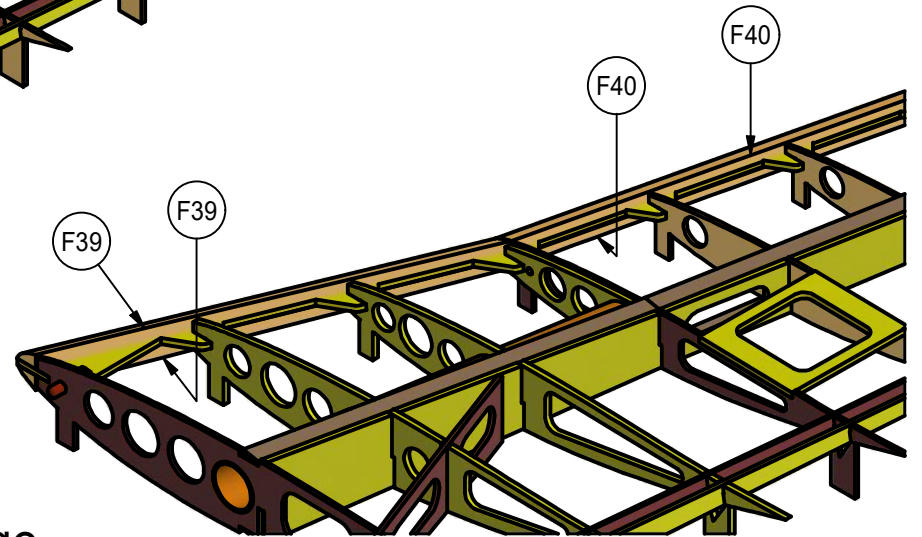

Building instructions wing

step 5
planking of the lower surface with
balsa 1.5mm thick

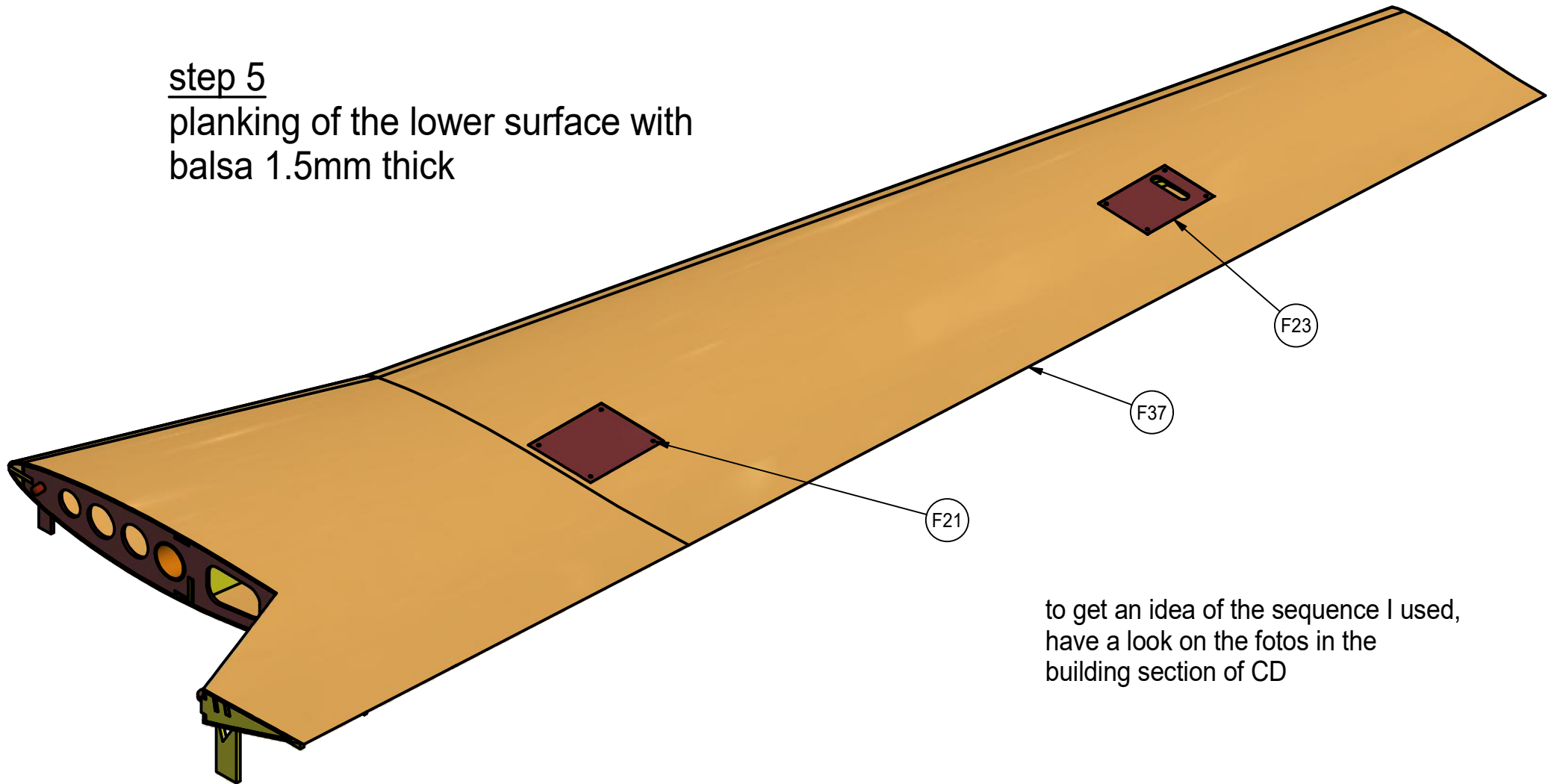

to get an idea of the sequence I used,
have a look on the fotos in the
building section of CD

Building instructions wing

step 6

Hinges for flaps (flaps not yet separated!)

mark correct position of slots in planking by stitching through a pin from the inside

check correct alignment of hinges by sliding a wire through all 3 hinges during bonding

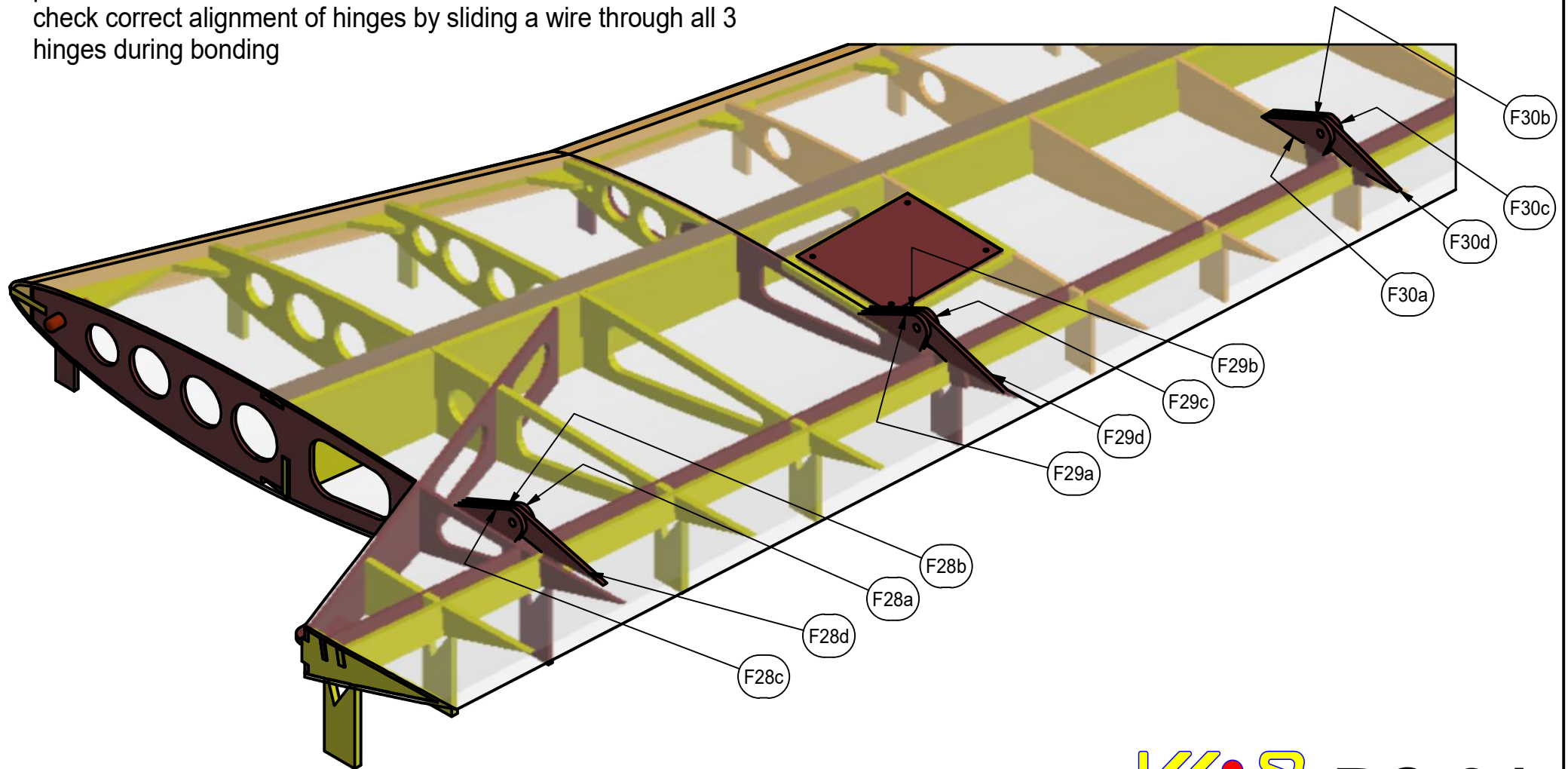

Building instructions wing

step 7

planking of upper surface
with balsa 1.5mm thick
+ wingtip of 3 F38

insert all cables before closing

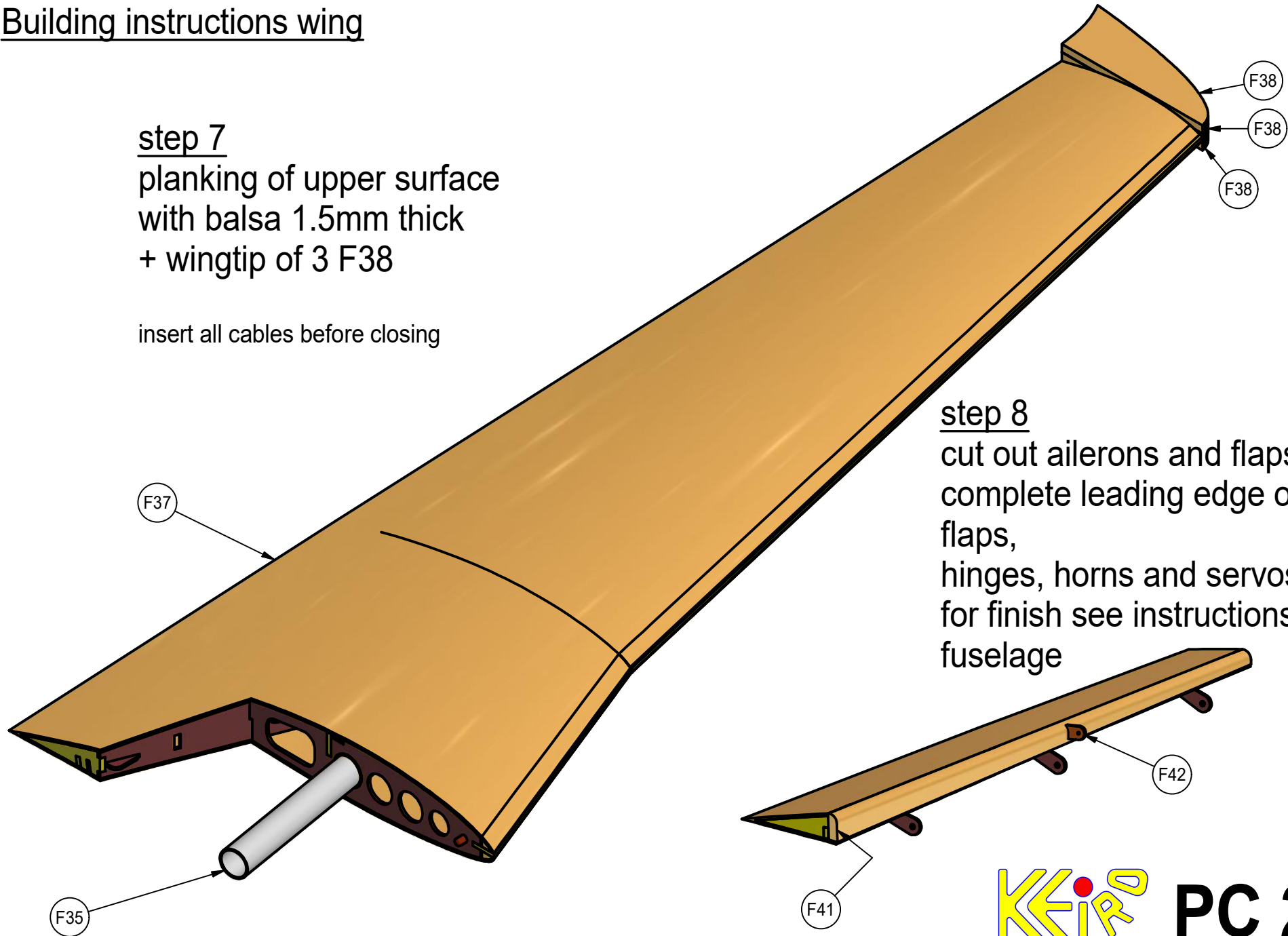

step 8

cut out ailerons and flaps,
complete leading edge of
flaps,
hinges, horns and servos
for finish see instructions of
fuselage

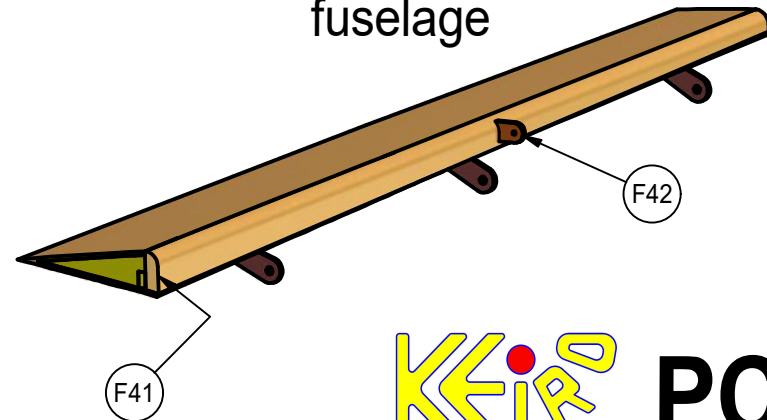

Building instructions wing

linking of flaps

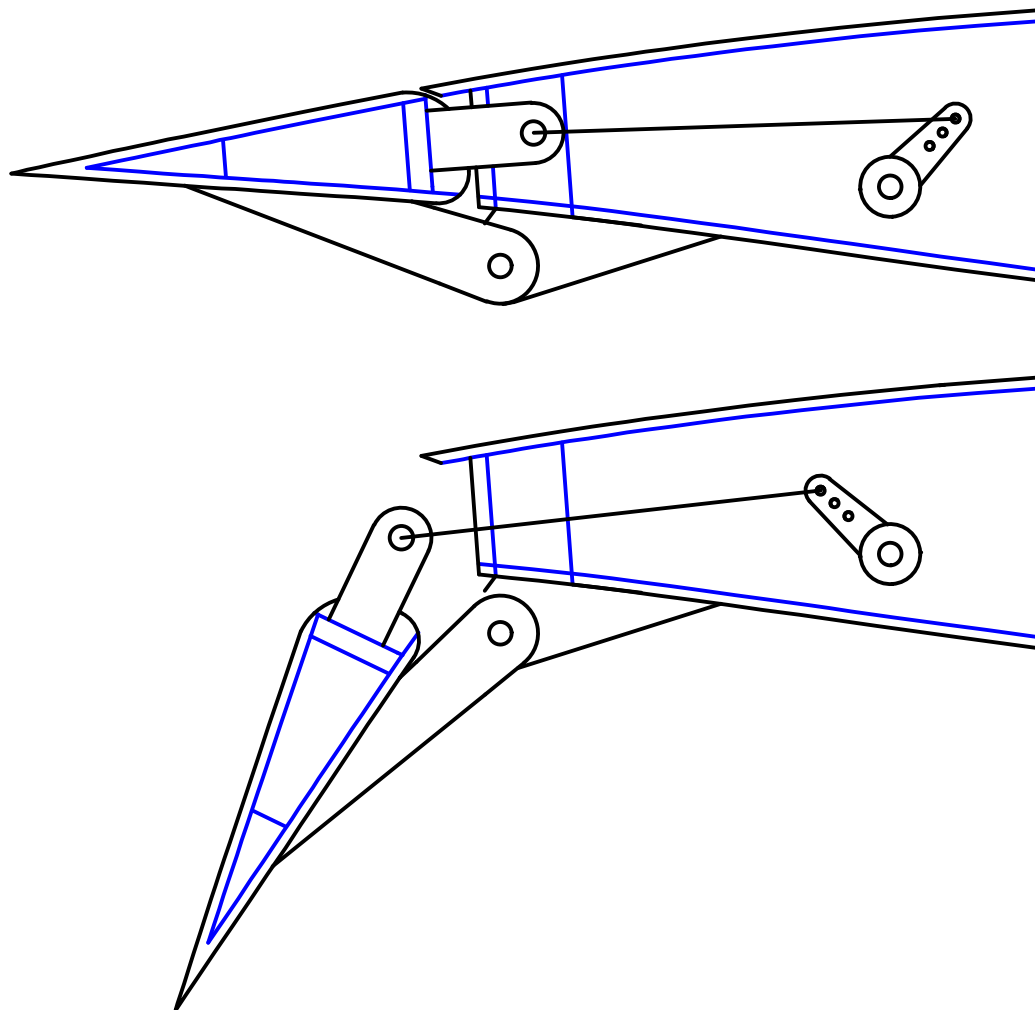

linking of ailerons

